

- $Q_n = 32 \text{ l/min} \dots 5600 \text{ l/min}$

AVENTICS Series CC01 Check-choke valves

The AVENTICS Series CC check-choke valves are designed for nominal flows from 32 to 5,600 l/min. The different versions are available with a push-in fitting or internal thread.

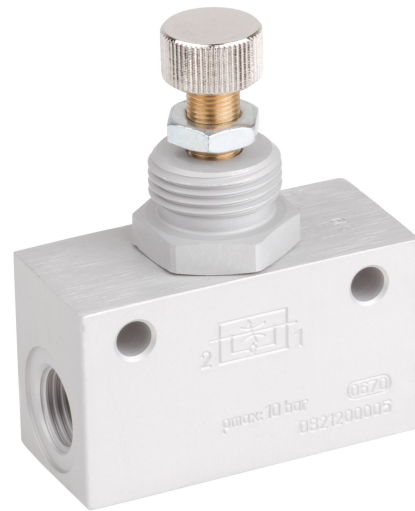

Technical data

Industry	Industrial
Port 1	G 3/8
Port 2	G 3/8
Throttle bore \varnothing	9 mm
direction of throttle	1 > 2 2 > 1
Nominal flow Q_n 1 to 2	1600 l/min
Compressed air connection type 1	Internal thread
Compressed air connection type 2	Internal thread
Medium	Compressed air
Min. working pressure	0.5 bar
Max. working pressure	10 bar
Min. ambient temperature	0 °C
Max. ambient temperature	80 °C
Min. medium temperature	0 °C
Max. medium temperature	80 °C
Weight	0.26 kg

Material

Housing material	Aluminum
Surface housing	anodized
Seal material	Acrylonitrile butadiene rubber
Material flow control screw	Steel, chrome-plated
Surface flow control screw	galvanized
Part No.	0821200014

Technical information

The min. control pressure must be adhered to, since otherwise faulty switching and valve failure may result!

The pressure dew point must be at least 15 °C less than ambient and medium temperature and may not exceed 3 °C.

The oil content of compressed air must remain constant during the life cycle.

Use only the approved oils from AVENTICS. Further information can be found in the “Technical information” document (available in <https://www.emerson.com/en-us/support>).

Dimensions

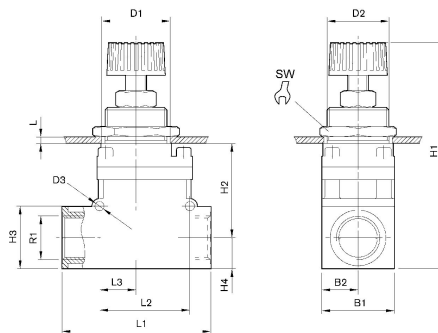

Part No.	Port G	R1	B1	B2	D1	D2	D3	H1	H2
0821200014	G 3/8	G 3/8	35	17.5	30.5	30	4.5	102-109	46

Part No.	H3	H4	L 1)	L1	L2	L3	SW
0821200014	30	15	12	72	44	18	36

1) Max.