

3/2-directional valve, Series AP

0820400008

Series AP

2024-01-21

- Lightweight and resilient valves
- Various mechanical actuating controls
- panel installation

Series AP - inch

Qn = [[150 ... 250] l/min]

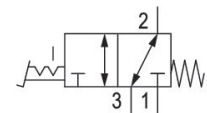
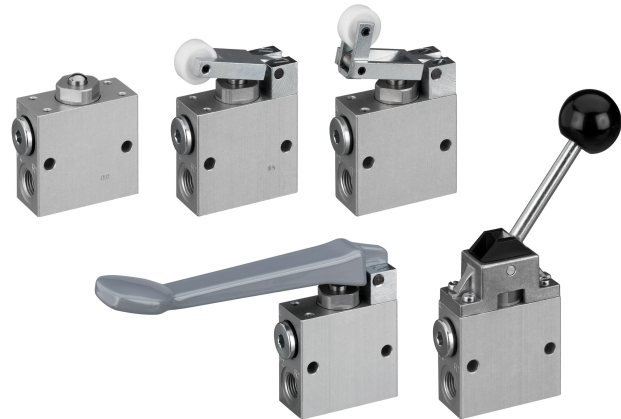

Technical data

Industry	Industrial
Activation	Mechanical
Valve type	Poppet valve
Plate connection	Pipe connection
Actuating element	Pedal, with detent
Compressed air connection type	Internal thread
Compressed air connection input	G 1/4
Compressed air connection output	G 1/4
Compressed air connection, exhaust	G 1/4
Nominal flow Qn	550 l/min
Min. working pressure	0 bar
Max. working pressure	10 bar
Min. ambient temperature	-30 °C
Max. ambient temperature	80 °C
Min. medium temperature	-30 °C
Max. medium temperature	80 °C
Medium	Compressed air
Min. oil content of compressed air	0 mg/m ³

3/2-directional valve, Series AP

Series AP

0820400008

2024-01-21

Max. oil content of compressed air	5 mg/m ³
Max. particle size	5 µm

Weight	1.22 kg
--------	---------

Material

Housing material	Aluminum
Seal material	Acrylonitrile butadiene rubber
Material actuating control	Aluminum
Part No.	0820400008

Technical information

Sound pressure level measured at 6 bar at 1 m distance

The min. control pressure must be adhered to, since otherwise faulty switching and valve failure may result!

The pressure dew point must be at least 15 °C less than ambient and medium temperature and may not exceed 3 °C.

The oil content of compressed air must remain constant during the life cycle.

Use only the approved oils from AVENTICS. Further information can be found in the "Technical information" document (available in <https://www.emerson.com/en-us/support>).

3/2-directional valve, Series AP

Series AP

0820400008

2024-01-21

Dimensions

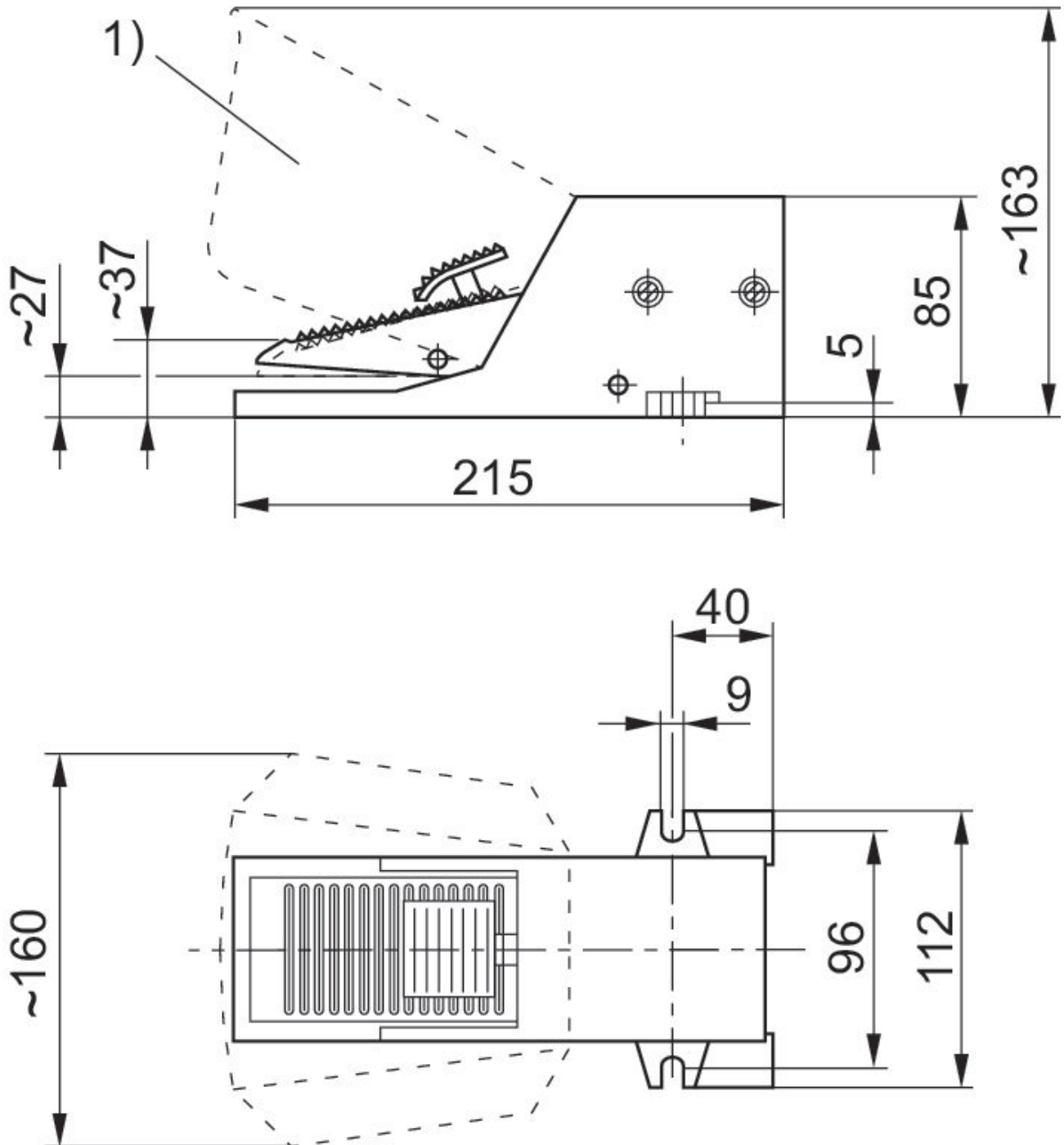

1) optional protective cover, part number 1828104002

Compressed air at port 3

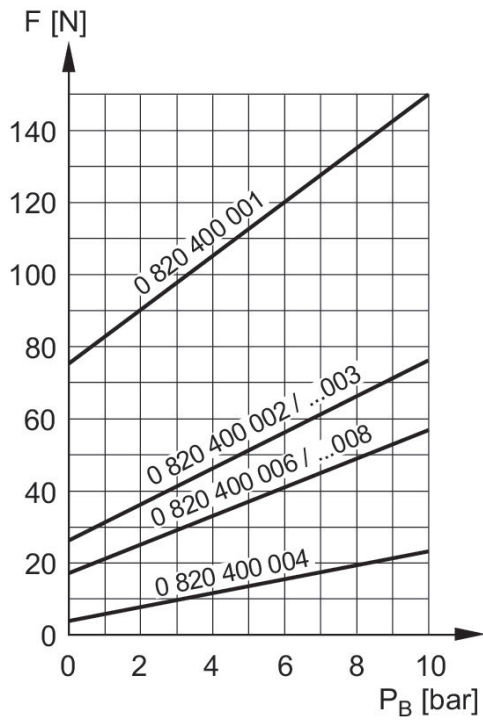

Actuating force+ Compressed air at port 1

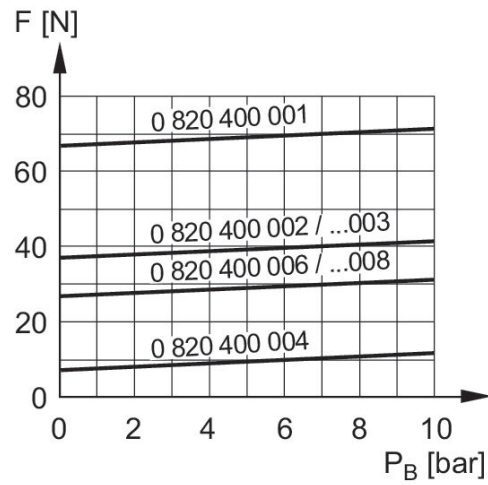

F = actuating force
 P_B = Working pressure