

0820055201

Series HF03-LG

The AVENTICS Series HF03-LG valve system is ideal for a variety of applications. It is versatile due to its wide connectivity and modularity.

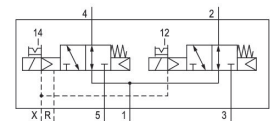
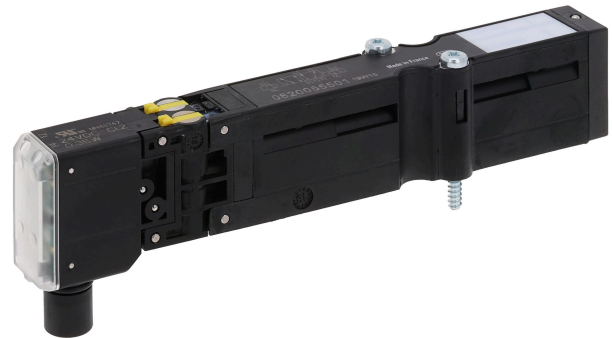

Technical data

Industry	Industrial
Activation	Electrically
Valve type	Spool valve, positive overlapping
Switching principle	2x 3/2 NO/NO, with spring return
Valve function	NO/NO
Sealing principle	Soft seal
Connection type	Plate connection
Manual override	with detent
Pilot control exhaust	With collective pilot air exhaust
Nominal flow Qn	850 l/min
Flow conductance b	0.22
Flow conductance C	2.97 l/(s*bar)
Min. working pressure	-0.9 bar
Max. working pressure	10 bar
Min. control pressure	3 bar
Max. control pressure	10 bar

2x3/2-directional valve, Series HF03-LG

2024-04-03

0820055201

Protection class with connection	IP65
Protective circuit	Z-diode
Reverse polarity protection	Protected against polarity reversal
Operational voltage	24 V DC
Operational voltage DC	24 V
Voltage tolerance DC	-15% / +20%

Pilot	External
Pilot valve width	16 mm
LED status display	Yellow
Power consumption DC	0.35 W

Duty cycle	100 %
Typ. switch-on time	20 ms
Typ. switch-off time	25 ms

Blocking principle	Single base plate principle
Certificates	UR (Underwriters Laboratories)
Min. ambient temperature	0 °C
Max. ambient temperature	50 °C
Min. medium temperature	0 °C
Max. medium temperature	50 °C
Medium	Compressed air
Min. oil content of compressed air	0 mg/m ³
Max. oil content of compressed air	5 mg/m ³
Max. particle size	5 µm

Mounting screws	cross recessed DIN EN ISO 4757-Z1
Mounting screw tightening torque	1.3 Nm
Weight	0.082 kg

Material

Housing material	Polyamide fiber-glass reinforced
Seal material	Acrylonitrile butadiene rubber
Part No.	0820055201

Technical information

The pilot type (external/internal) is not implemented in the valve, but in the end plate of the valve system.

The pilot valve is UL (Underwriters Laboratories) certified.

The min. control pressure must be adhered to, since otherwise faulty switching and valve failure may result!

The pressure dew point must be at least 15 °C less than ambient and medium temperature and may not exceed 3 °C.

The oil content of compressed air must remain constant during the life cycle.

Use only the approved oils from AVENTICS. Further information can be found in the "Technical information" document (available in <https://www.emerson.com/en-us/support>).

2x3/2-directional valve, Series HF03-LG

2024-04-03

0820055201

Dimensions

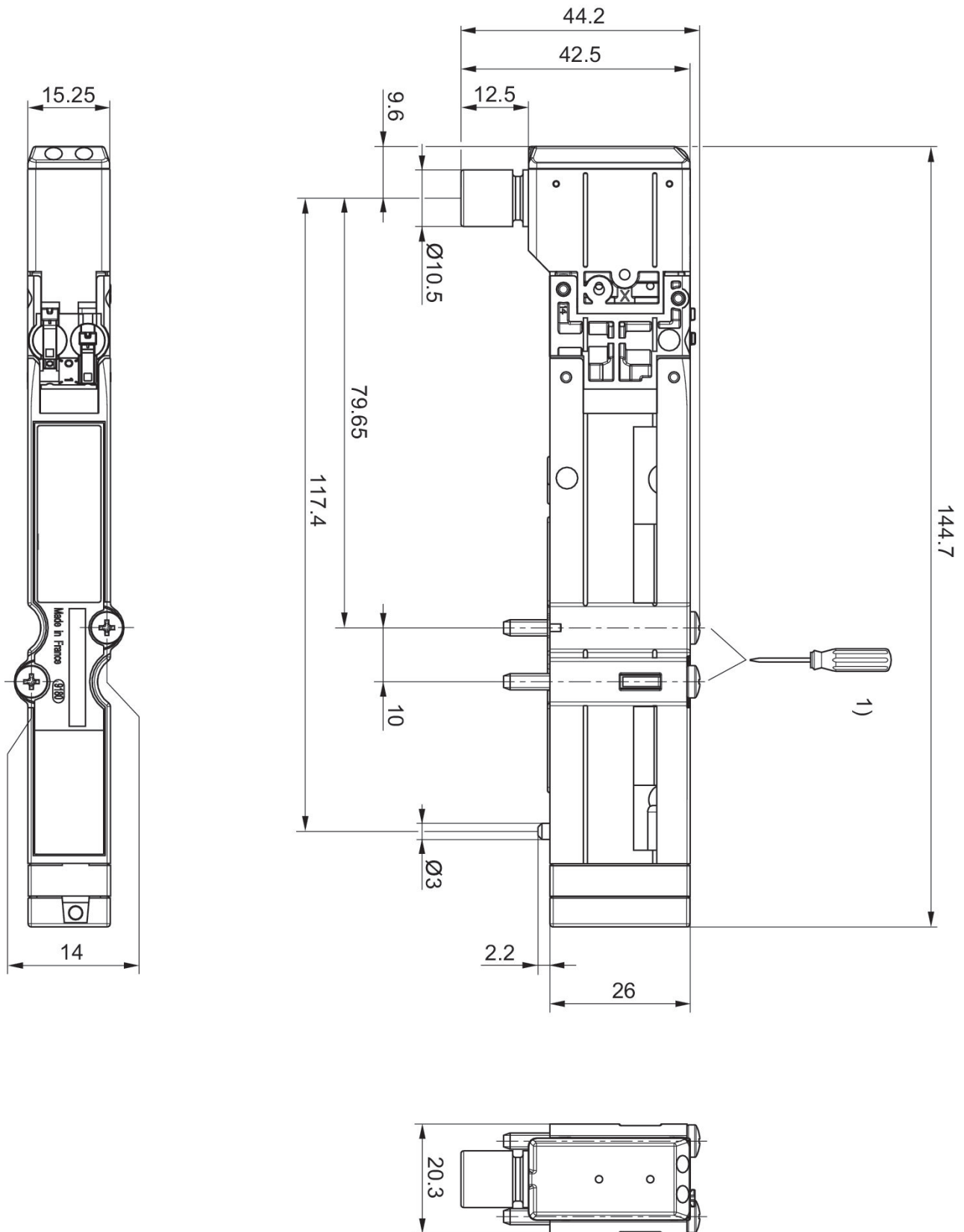

1) = 1.1 +0.2 Nm 800tr/min. max.