

- Ø 32 mm ... 320 mm

## AVENTICS Modular scraper systems and front lube unit

The AVENTICS Modular scraper system and front lube unit offer more flexibility by implementing a different scraper model with the same cylinder if yours needs changing. They are available separately as spare parts with fully installed seals and bushings and can be exchanged at any time, quickly and easily, without removing the cylinder.



### Technical data

Industry

For series

Scraper

Application area

Piston Ø

Min. working pressure

Max. working pressure

Min. ambient temperature

Max. ambient temperature

Medium

Min. oil content of compressed air

Max. oil content of compressed air

Industrial

PRA

TRB

CCL-IS

Chemical-resistant scraper

Textile industry

Food industry

Chemical industry

Sugar production

125 mm

1.5 bar

10 bar

-20 °C

80 °C

Compressed air

0 mg/m<sup>3</sup>

5 mg/m<sup>3</sup>

### Material

Housing material

Aluminum

# Modular scraper system

0496301706

Series MS

2023-12-20

Surface

anodized

Piston rod seal

Acrylonitrile butadiene rubber

Scraper

Polytetrafluoroethylene

Part No.

0496301706

## Dimensions

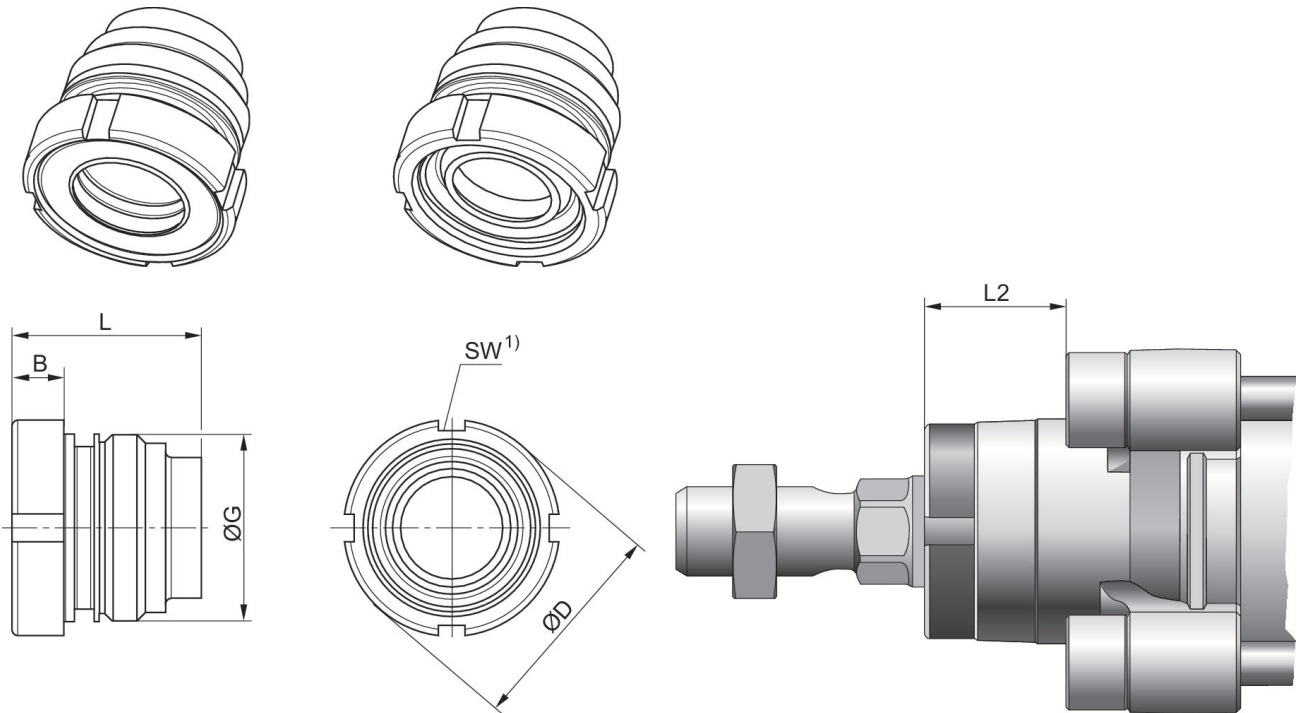

1) Can be mounted with hook wrench in accordance with DIN 1810 A

Piston Ø	B	ØD	G	L	L2	SW
50, 63	9	38.5	M33x2	33.5	25	40-42
80, 100	10	44	M40x2	44	33	45-50
125	12	57	M50x2	56	45	58-62